

RAPISCAN HE50

An Innovative, Truly Hand-held
Explosive Trace Detection (ETD) System

Lightweight, Compact, and User-Friendly Design

Low Cost of Operation - Few Consumables, Minimal Maintenance

Sensitive with Low False Alarm Rate

Fast Real-Time Detection



The Rapiscan HE50 delivers a lightweight and ergonomically designed, low cost threat detection tool to military, law enforcement, event, border and infrastructure protection personnel in their efforts to combat terrorism. With proven, future proofed, Ion Mobility Spectrometry (IMS) technology and its patent-pending design and operational innovations, the HE50 provides true hand-held explosive trace detection capabilities, compared with other commercially available portable IMS-based detectors on the market today.

Operational Flexibility with Advanced Sampling Technology

The Rapiscan HE50 can detect explosive trace in both particulate and vapor form from the ambient environment or any surface that may have absorbed explosive residues. In addition to traditional swipe sampling collection methodology, the HE50 makes possible use of a touch-free inhalation sampling method for situations where physical contact with the subject is inappropriate or not possible. With its operational flexibility, real-time analysis response, and fast, reliable and specific identification of explosive threats, the HE50 can support a variety of screening scenarios, whether vehicle/people checkpoints, mail screening, cargo, etc.

Detects Broad Range of Explosives

The Rapiscan HE50 detects minute traces of a broad range of common commercial and homemade explosive materials, including nitrates, peroxides, plastic explosives, and their associated taggants. With a low false alarm rate, the HE50 is capable of detecting, alarming on, and recording all threat results—even when multiple explosive materials are found during the same screening instance. Armed with the HE50, screening personnel are able to focus on investigation of valid alarms while having the threat analysis automatically documented for evidentiary purposes.

Reduced Total Cost of Ownership

Designed to minimize operating costs, the HE50 eliminates the majority of consumables and preventive maintenance requirements that are typically associated with ETD's. No grids, membranes, drying agents or calibration traps are required.

Real Time Detection

Features including fast start-up time, fully automatic continuous self-calibration, and an optional continuous sampling mode, all make the HE50 ideal for security situations where both high throughput and high detection probability are required.

Easy-to-Operate

Ready to use in less than 10 minutes, with an automated start-up process, an intuitive operating interface and 3-button control, the HE50 also has no standard daily preparation, cleaning or maintenance task requirements. Alarms can be configured with audible and/or visual detection indicators, on a LCD screen protected by impact-resistant glass, enabling the HE50 to be used in all light conditions and remain resistant to the scratches, drops, and bumps of everyday use.

Exempt from US NRC Requirements

The HE50 uses a unique ionization source with US Nuclear Regulatory Commission (NRC) Exempt Distribution status that has no end-user radiation licensing requirements for use within the United States. International operators should check with their nuclear regulatory agency for local requirements.



HE50 analyzing sample trap after swipe method collection.



Scanning subject using non-contact, inhalation sampling.

Applications

- Critical Infrastructure
- Customs and Border Protection
- Defense
- Event Security
- Law Enforcement
- Ports

Rapiscan[®]
systems

An OSI Systems Company

www.rapiscansystems.com

RAPISCAN HE50

Specifications

Scan/Analysis Time	3 to 30 seconds
Sample Acquisition	Trace particulate and vapor. Contact and non-contact sample collection. Continuous sampling and Timed sampling modes.
Explosives Detected	All major classes of explosives, including but not limited to TNT, C4/RDX, Semtex.
Cold Start-up Time	Under 10 minutes
Operating Temperature	-20°C to +55°C
Relative Humidity	1 to 99.5 % R.H. (non-condensing)
Battery Specification	Fast full charge lithium ion battery in 2.5 hours for 3 hours of continuous operation
Battery Capacity and Voltage	4300mAh at 14.4V
Product Dimensions (with battery)	Length: 278 mm (10.9 in.) Width: 141 mm (5.6 in.) Height: 274 mm (10.8 in.)
Product Weight	1.9 kg (4.2 lbs) with the battery
Case Dimensions	Length: 508 mm (20 in.) Width: 406.4 mm (16 in.)
Case Packing Weight	6.6 kg (14.5 lbs)

Product Standards and Compliance

UL/cUL 61010-1	ISO 2919:1999
CE Compliance	NUREG 1556, V3, R1
IEC 61010-1	FCC Title 47 CFR Part 15
IEC 61326-1	CB Scheme
ANSI/HPS N43.8:2008	Tested to MIL-STD-810

Regulatory

Subject to dual-use export licensing from U.S. & U.K. and radioactive licensing to destination countries. Some exemptions apply.

Kit Components

The Rapiscan HE50 Hand-held Trace Explosive Detector kit comes standard with the following:

HE50 (1 unit)	Sample Traps (100 count)
Hard Shell Storage Case	TNT Confidence Samples (2)
Lithium Ion Battery Pack (2)	Reporting Software CD
Battery Charger	Micro USB Cable
Shoulder Strap	HE50 Operator Manual
Dopant Vials (2 x pack of 6)	

Additional component items and consumables are available as needed after initial kit delivery.

With continual development of our products Rapiscan Systems reserves the right to amend specifications without notice. Product pictures are for general reference. Please note that due to US laws and regulations, not all Rapiscan products are available for sale in all countries without restriction. Please contact your Rapiscan Systems sales representative for more information.

Rapiscan[®]
systems

An OSI Systems Company

ONE COMPANY - TOTAL SECURITY

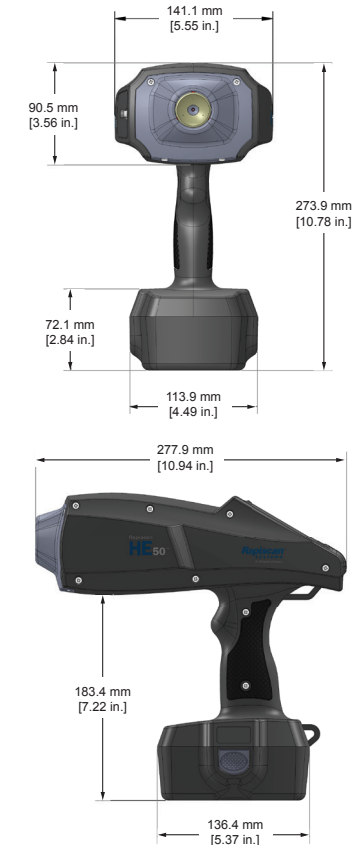

AMERICAS, CARIBBEAN

2805 Columbia Street
Torrance, California 90503
UNITED STATES OF AMERICA
Tel: +1 310-978-1457
Fax: +1 310-349-2491

EUROPE, MIDDLE EAST, AFRICA

X-Ray House
Bonehurst Road
Salfords
Surrey RH1 5GG
UNITED KINGDOM
Tel: +44 (0) 870-7774301
Fax: +44 (0) 870-7774302

ASIA

240 Macpherson Road
#07-01 Pines Industrial Building
Singapore 348574
SINGAPORE
Tel: +65-6846-3511
Fax: +65-6743-9915

EMAIL

sales@rapiscansystems.com

WEB

www.rapiscansystems.com



Rapiscan Systems is
ISO 9001:2008 Certified

www.rapiscansystems.com